

FFI RAPPORT

TESTING OF STANAG 4538 (3G HF) IMPLEMENTED IN HARRIS RF-5800H

JODALEN, Vivianne, GRØNNERUD Ove

FFI/RAPPORT-2005/01182

**TESTING OF STANAG 4538 (3G HF)
IMPLEMENTED IN HARRIS RF-5800H**

JODALEN, Vivianne, GRØNNERUD Ove

FFI/RAPPORT-2005/01182

FORSVARETS FORSKNINGSINSTITUTT
Norwegian Defence Research Establishment
P O Box 25, NO-2027 Kjeller, Norway

FORSVARETS FORSKNING SINSTITUTT (FFI)
Norwegian Defence Research Establishment

UNCLASSIFIED

P O BOX 25
 NO-2027 KJELLER, NORWAY
REPORT DOCUMENTATION PAGE

SECURITY CLASSIFICATION OF THIS PAGE
 (when data entered)

1) PUBL/REPORT NUMBER FFI/RAPPORT-2005/01182 1a) PROJECT REFERENCE FFI-II/822/110	2) SECURITY CLASSIFICATION UNCLASSIFIED 2a) DECLASSIFICATION/DOWNGRADING SCHEDULE -	3) NUMBER OF PAGES 36		
4) TITLE TESTING OF STANAG 4538 (3G HF) IMPLEMENTED IN HARRIS RF-5800H				
5) NAMES OF AUTHOR(S) IN FULL (surname first) JODALEN, Vivianne, GRØNNERUD Ove				
6) DISTRIBUTION STATEMENT Approved for public release. Distribution unlimited. (Offentlig tilgjengelig)				
7) INDEXING TERMS IN ENGLISH: <table style="width: 100%; border: none;"> <tr> <td style="width: 50%; vertical-align: top;"> a) <u>STANAG 4538</u> b) <u>3G HF Radio</u> c) <u>ARCS Trials</u> d) <u>RF-5800H</u> e) <u>HF standards</u> </td> <td style="width: 50%; vertical-align: top;"> IN NORWEGIAN: a) <u>STANAG 4538</u> b) <u>3G HF Radio</u> c) <u>ARCS testing</u> d) <u>RF-5800H</u> e) <u>HF standarder</u> </td> </tr> </table>			a) <u>STANAG 4538</u> b) <u>3G HF Radio</u> c) <u>ARCS Trials</u> d) <u>RF-5800H</u> e) <u>HF standards</u>	IN NORWEGIAN: a) <u>STANAG 4538</u> b) <u>3G HF Radio</u> c) <u>ARCS testing</u> d) <u>RF-5800H</u> e) <u>HF standarder</u>
a) <u>STANAG 4538</u> b) <u>3G HF Radio</u> c) <u>ARCS Trials</u> d) <u>RF-5800H</u> e) <u>HF standards</u>	IN NORWEGIAN: a) <u>STANAG 4538</u> b) <u>3G HF Radio</u> c) <u>ARCS testing</u> d) <u>RF-5800H</u> e) <u>HF standarder</u>			
THESAURUS REFERENCE:				
8) ABSTRACT <p>NATO has produced a number of standards (STANAG's) for HF communications. Among these is STANAG 4538 "Technical Standards for an Automatic Radio Control System (ARCS) for HF Communications Links", also called 3G HF technology. The NATO group expressed strong interest in seeing test results from over-the-air testing of this STANAG, and a three-nation test group was formed. The UK, NL and Norway established six radio stations in the respective countries and performed joint testing of the Harris implementation of STANAG 4538 (RF-5800H). The main conclusions are: Compared to 2G HF represented by Mil-Std 188-141A, Fed-Std 1052 and Mil-Std 188-110A, the S4538 outperforms 2G by more than doubling the throughput for large files and showing robust performance during bad channel conditions. Link setup gives particularly enhanced performance with reduced linking times and increased robustness. A considerably worse performance was observed on the high latitude path than on the mid-latitude paths. Good connectivity was achieved between all nodes of the network using a one-way point-to-multipoint link setup. Sounding and the use of channel scores is an important tool for rapid linking at a good frequency.</p>				
9) DATE 2005-04-15	AUTHORIZED BY This page only Vidar S Andersen	POSITION Director		

ISBN 82-464-0944-1

UNCLASSIFIED

SECURITY CLASSIFICATION OF THIS PAGE
 (when data entered)

CONTENTS

	Page
1 INTRODUCTION	7
2 AIMS OF THE TESTING	8
3 STANAG 4538, TECHNICAL OVERVIEW	9
3.1 The Link setup	9
3.2 The data link protocol	10
3.3 The Waveforms	11
3.4 The Harris RF-5800H implementation of S4538	12
4 TEST SETUP	12
4.1 Test software	15
4.2 Test parameters	16
5 TEST PHASES	16
6 RESULTS	17
6.1 xDL versus 2G (Fed-Std 1052 + Mil-Std 188 110A) on a point-to-point link	17
6.2 3G (FLSU and xDL) vs 2G (Mil-Std 188 141A and Fed-Std 1052) on a point-to-point link	18
6.2.1 Results on mid-latitude paths	19
6.2.2 Results on the high latitude path Jan Mayen – Jørstadmoen (1360 km)	21
6.3 Point-to-Multipoint one-way LSU	27
6.4 TOD synchronisation	31
7 CONCLUSIONS	31
References	34

TESTING OF STANAG 4538 (3G HF) IMPLEMENTED IN HARRIS RF-5800H

This report documents one activity of FFI Project 822 SIGVAT HF, performed during the years 2001-2004. There exist two companion reports; “NATO Standards for HF Communications – an overview and technical description” (1) and “Performance testing of STANAG 4406 (Military Messaging) using IP over HF” (2).

1 INTRODUCTION

During the 1990’s, many STANAG’s (Standard Agreements) on HF communications have been developed and agreed upon within NATO. The standards cover the lowest layers of the OSI model containing radio functionality, modem waveforms, datalink protocols and some networking aspects. Some of the standards are very complex. A technical overview of the various NATO STANAG’s and American Military Standards (Mil-Std) are given in (1).

Among the more complex STANAG’s are STANAG 4538 (3): “Technical standards for an automatic radio control system (ARCS) for HF communication links (Edition 1)”. The technology described in this STANAG is called 3rd generation automated HF (3G HF) and in NATO also known as ARCS (Automated Radio Control System). The STANAG was developed by a standardization group within NATO (AC322/WG6/AHWG1) consisting of governmental representatives, industry and academia, with the latter two providing the largest input to the technical work. Harris Corporation in the US was deeply involved in the standardization process, and some technical solutions of the Harris product line were adopted by the standard. Harris Corp was then in a good position to implement the new standard, and in 2001 they had a partial implementation ready. Not until 2004 another vendor (Telefunken Racoms, GE) had an implementation of S4538 ready.

The standardization group realized a need for over-the-air testing of a complex system like S4538, and in the year 2000, a three-nation test group was formed. The three nations expressing their interest in testing the new STANAG, were the United Kingdom, the Netherlands and Norway. The UK and NL had already, or were about to sign contracts with Harris on procurement of the Harris RF-5800H radio. At that time, Norway was not in a procuring phase, but in 2003 the Norwegian Army signed a contract for procuring Harris RF-5800H radios (P5473 “HF Interimsløsning”).

The cooperating parties from the three nations have been QinetiQ Malvern (former DERA) in the UK, TNO-FEL in the NL and FFI. The same three nations and institutions participate in the ANN CP (Anglo-Netherlands-Norwegian Cooperation Program) so the common testing of STANAG 4538 has been discussed during meetings of the Anglo-Netherlands-Norwegian Cooperation Program (ANN CP 1,24) as well.

Each institution had two radios available each, altogether six radios. There has been both individual testing in each country and joint testing using all six radios deployed in the respective countries, including Jan Mayen, Norway. The main contribution to the tests from FFI was testing of the equipment at high latitudes where Norwegian forces have special interest. Figure 1 shows the radio sites used during the tests.



Figure 1 Radio sites during the three-nation ARCS tests (Norwegian mainland site was at Jørstadmoen close to Lillehammer, and not in Oslo as indicated on the map)

2 AIMS OF THE TESTING

The overall aim of the over-the-air testing has been to explore the possibilities of S4538 and recommend usage to military forces. To achieve this, the goals have been:

- To test efficiency of the 3G protocols and compare it with the 2G protocols
- To investigate configuration and optimization issues
- To provide guidance on application under various scenarios
- To provide feedback for future enhancements to the standard and the implementations

3 STANAG 4538, TECHNICAL OVERVIEW

A technical overview of STANAG 4538 is given in (1). Here a short version is given for the completeness of this report.

The term “third generation” automated HF implies:

- All HF stations in the network are equipped with accurate clocks and perform synchronous scanning of a set of pre-assigned frequencies. All stations visit the same frequency simultaneously, enabling very rapid linking.
- A highly efficient Automatic Repeat reQuest data link protocol is combined with several robust waveforms which are optimised for the data link protocol. The robustness of the communication adapts itself to the channel conditions by means of *code combining*.

The standard is located at the two lowest layers of the OSI model. The data link protocol at layer two is closely connected with the burst waveforms defined in the standard, and cannot be run with other waveforms. On the other hand, the link set up, which is also located at layer two, can be run in conjunction with other data link protocols, for example STANAG 5066 (4), and with other waveforms. In this case, STANAG 4538 establishes a circuit-switched connection, which STANAG 5066 or the waveforms make use of.

3.1 The Link setup

Two different protocols are prescribed for link set up in STANAG 4538; FLSU (Fast Link Set Up) and RLSU (Robust Link Set Up). RLSU will not be described further here since our implementation does not contain this functionality.

Compared with RLSU, FLSU is a faster link set up protocol and is intended for use in lightly-to-medium loaded networks. The core of both FLSU and RLSU is that all members of the HF network synchronously scan a set of pre-defined frequencies using an accurate time reference. A station that wants to contact another station decides which frequency it will use, jumps to that frequency immediately before the other HF stations arrives at it to check that it is free, and transmits a signal as soon as the other stations have arrived at that frequency. The dwell time at each frequency is 1.35 seconds, and the link set up is a two-way “handshaking”. Some of the possibilities available in connection with link set up are:

- Point-to-point for packet data transmission
- Point-to-point for circuit-switched data transmission
- Point-to-multipoint for circuit-switched data transmission
- An unsynchronised station (without GPS time) can call up a synchronised station
- An unsynchronised station can call up and become synchronised with a station or network which is synchronised.

3.2 The data link protocol

The STANAG 4538 data link protocol is an ARQ protocol which can only be run in a point-to-point data packet connection. The data link protocol is designated xDL and is actually a family of protocols which can be grouped as HDL (High throughput Data Link) and LDL (Low latency Data Link) protocols. HDL is most efficient when large volumes of data are to be transmitted and the channel conditions are moderately good. LDL works best when transmitting small data volumes (irrespective of channel conditions) and when the channel is of poor quality (irrespective of data volume). However, in the latter case, it will take a long time for LDL to transmit a large data volume.

HDL and LDL protocols can be designated by a number, as in HDL3 or LDL512. The link protocol divides up the data volume to be transmitted into blocks of a given size. The number in the designation of HDL protocols signifies the number of 233-byte blocks (called packets) which are transmitted in one forward frame. For example, HDL3 transmits 3×233 bytes in a forward frame. The receiver then returns an acknowledge signal (ACK) for the receipt of this frame and indicates if necessary which of the packets in the frame contained errors (selective acknowledgement). The transmitter will then retransmit these packets in the next forward frame. For LDL, the number at the end of the designation signifies the actual number of bytes which are transmitted in one forward transmission. The acknowledgement signal states whether or not the entire transmission was successful; in other words, no selective ACK is provided. The size of the forward transmission can vary from 32 bytes (LDL32) to 5592 bytes (HDL24).

“Throughput” is a measure of how efficiently the data link protocol, in combination with the waveforms, transmits data. The throughput falls if the channel conditions make it necessary to retransmit packets many times. The maximum throughput of a link protocol is achieved when transmitting a large data file by the largest frame through an error-free channel; the time spent for establishing and releasing the link is then minimal in comparison with the time taken to transmit traffic, and there are no retransmissions. For HDL24, the maximum throughput is approximately 3200 bits/s and for LDL512 it is approximately 400 bits/s. The theoretical throughput of the HDL and LDL protocols as a function of message size are given in Figure 2 and 3. These curves include the time to establish and release the link.

xDL is a code-combining ARQ protocol. This means that the initial transmission of a packet is transmitted uncoded. If the packet is received with errors, a coded version of the packet is transmitted next time. This can be repeated several times until finally the receiver has a number of “versions” of the packet. The different versions can then be combined to derive the actual data, thereby increasing the probability of correct decoding.

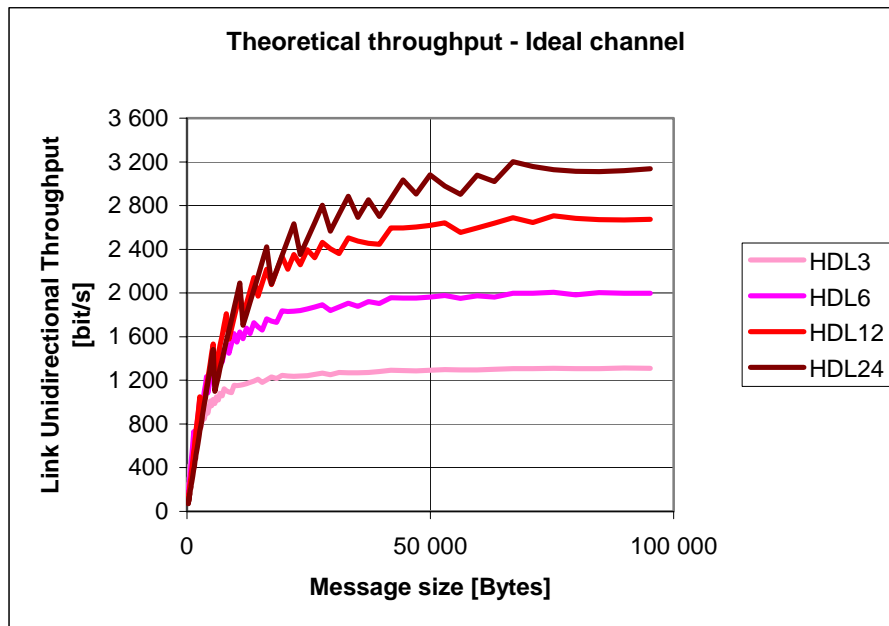

Figure 2 Theoretical performance of HDL protocols

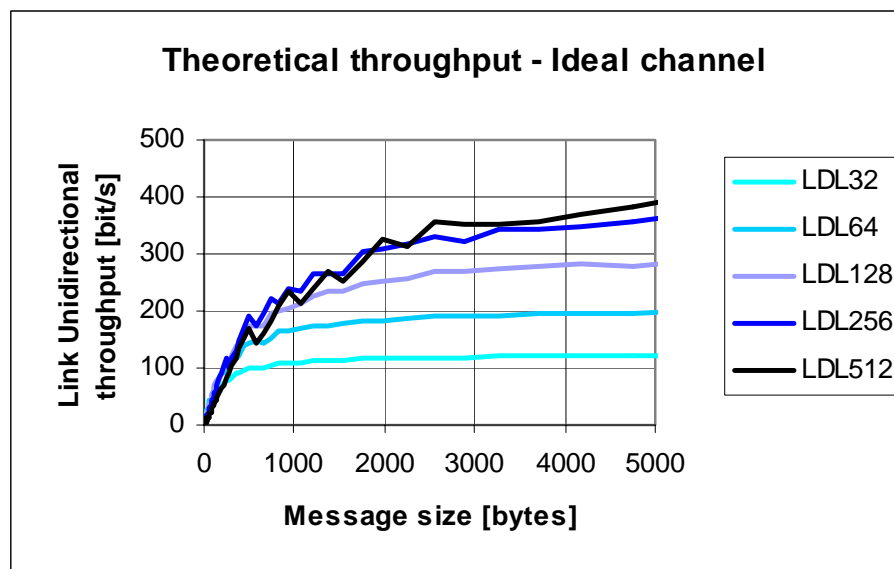

Figure 3 Theoretical performance of LDL protocols

3.3 The Waveforms

The difference in robustness between HDL and LDL is the result of the different waveforms which are used. The data link protocol is closely associated with the burst waveforms defined in the standard and which are located at layer one of the OSI model. Six burst waveforms (BW) are defined which are used in different contexts:

- BW0 for Robust Link Set Up
- BW1 for management traffic and HDL ACK
- BW2 for HDL traffic

- BW3 for LDL traffic
- BW4 for LDL ACK
- BW5 for Fast Link Set Up

All have different technical characteristics in terms of code rate, interleaving, frame format and synchronisation, and this gives them varying degrees of robustness. The most robust waveforms are used for the ACK signals, as it is important for the protocol efficiency that these are received correctly. The waveforms for link set up are also more robust than the traffic waveforms, hence even if a link is established it may still be impossible to transmit traffic. Typically, HDL (BW2) must have positive SNR values to work, while LDL (BW3) can handle SNR's down to -7 dB. The maximum gross data rate obtained for the HDL waveform is 4800 bit/s. The duration of a burst varies for the different waveforms, for example, an ACK for LDL takes about 0.5 seconds, while an HDL24 traffic frame takes about 10 seconds to transmit.

3.4 The Harris RF-5800H implementation of S4538

Our primary goal was to test the capabilities of S4538. However, practical testing is not possible without an implementation, and the Harris implementation of S4538 in their RF-5800H was chosen due to its early availability. The measured performance reported in this paper is therefore not only associated with the STANAG itself, but also with the specific implementation of it. An example of a parameter that is *implementation specific* and is of importance to the measured performance is the Automatic Channel Selection algorithm.

S4538 requires an IP packet interface to be provided, but does not specify this interface in detail. In the RF-5800H, a direct IP interface is implemented, and the radio act as an IP router for IP traffic.

4 TEST SETUP

The test setup on a point-to-point link is shown in Figure 4, and a detailed block scheme for one station is given in Appendix A. At each site an Ethernet connection was established between the RF-5800H, a PC and a modem (which was a combined router/modem). Each unit had its own IP address. The PC served to program the radio, ran the test software including scripts and stored the measurements to disk. The modem connected to the public telephone network was used to remotely control other nodes of the HF network, for instance to upload test scripts and download result files. Embedded GPS provided accurate synchronization of the radios. The radios can provide a maximum output power of 20 W, whereas the power amplifier used during most of the over-the-air tests can give up to 125 W. HF antennas appropriate for the desired range of communications were used.

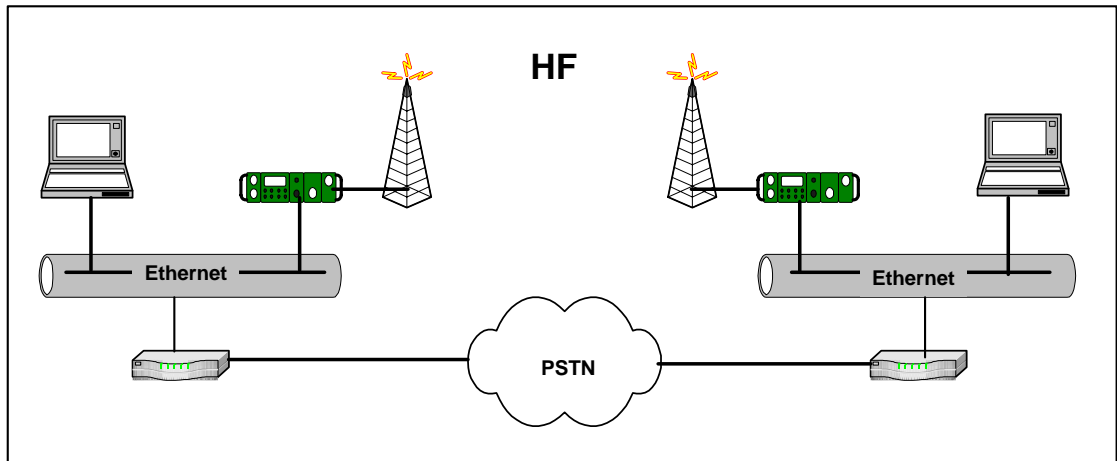

Figure 4 Test setup between two nodes in the ARCS network

A complete list of equipment bought by FFI for the tests is as follows:

2 RF-5800H

2 125 W RF-5632H Power Amplifiers

3 Netgear Routers

1 ICOM AH-710 broadband dipole

2 Lap tops

1 fast-tune antenna coupler RF-382A (not used)

1 HF NVIS Antenna System RF-1938 AT (not used)

At the Norwegian sites we used an inverted V antenna fitted for the frequencies 3.9, 4.8 and 6.7 MHz at Kjeller, and broadband dipoles at Jørstadmoen and Jan Mayen.



Figure 5 Broadband dipole used at Jan Mayen



Figure 6 Test setup at each node in the network. RF-5800H, PC, 125 W Power Amplifier, power supply, PTT-box and Netgear router/modem

For the three-nation tests, the setup was similar to Figure 4. Each station in the HF network had its own designated name with an associated IP address plan. The geographical locations involved and the associated station names are given in the table below.

Malvern, UK	UKB
Portsmouth West/Cove, UK	UKR
Maaldrift, NL	NEB
Den Helder, NL	NER
Kjeller/Jan Mayen, NOR	NOB
Jørstadmoen, NOR	NOR

Table 1 Geographical locations and associated station names (B-base, R-remote)

4.1 Test software

Harris had developed a Visual Basic test control software that enabled two geographically spaced radios to be configured and controlled remotely via the telephone network. This required a dedicated continuous phone line throughout the duration of the testing. The software provided all the TCP/IP functionality to communicate with the radios, and the embedded SNMP protocols enabled remote access to any locally or remotely connected radio. In addition, the software acted as a test development application.

QinetiQ added new functionality to the test software enabling it to read and execute script commands without being dependent on a dedicated phone connection. Remote dial-up access using PCAnywhere allowed uploading of the same script file to all stations of the network, start of each test script and retrieval of the test results. Using the QinetiQ test software each radio was controlled by their local PC using SNMP. The embedded GPS was used to accurately synchronise script commands.

As an example a script line for a certain test contained the following:

Scheduled time: 12:05

Transmitter station: UKB (S4538 address)

Receiver station: NOR (S4538 address)

Data link protocol: HDL24

File size: 500 (bytes)

Channel: 1

After reading the script line, the test software created a file of the specified size within the memory of the radio, using a radio control command. It then updated the PC-clock with GPS-time, triggered the radio to send the message and read the current time into a database file. During the transmission, the status information over the Telnet connection was monitored, and events like “Linked”, “Message completed”, “Frequency selected” were noticed and the data with corresponding times were logged to the database file. Then another script line was executed at the next scheduled time. Merging the database files at the two ends of the link and post processing the data gave the test results.

The QinetiQ test software also enabled the user to transmit and analyse a received channel probe. The channel probe was a 5 seconds Barker-13 sequence and it resided on the PC in the form of an audio.wav file. A sound card hosted by the PC was used to transmit and receive the channel probe. In order to generate an external Push-To-Talk (PTT) on the radio, a control signal was provided by an external PTT box (not shown in Figure 4, but detailed in Appendix B).

Also, a 10 seconds CW signal could be transmitted, and local noise could be monitored.

4.2 Test parameters

Throughput was the primary performance metric. It was measured as the size of the transmitted file divided by the time of transfer including link setup time (when link setup was included in the radio software) and link termination time.

The measured *Call times* were recorded as the time from initiation of a link to the link was established. Also the *frequency*, number of *link attempts*, *link successes* and *send successes* were noted and written to the database file. The measured *SNR* is an average value of all the *SNR*'s reported in the Telnet window during a message transfer. It is considered not to be very accurate.

From the probe measurements, a better estimate of the *SNR* could be made, in addition to the number of propagating modes, multipath spread, Doppler spread and noise.

5 TEST PHASES

The over-the-air testing started in 2001 and has gone through different phases depending on available functionality of the radio software/hardware provided by Harris. In parallel to the three-nation testing described here, Harris has expanded their radio with new S4538 functionality and made early versions of new functionality available to us. However, as of today (Jan 2005), there exists no complete implementation of S4538.

During the different test phases, the tests have partly taken place in each nation and partly between the three countries.

Phase 1, April 2001 - December 2001

The focus of this phase was to measure the performance of the data link protocol xDL of S4538, and compare it with the performance of 2G technology represented by Fed-Std 1052¹ (data link protocol) and Mil-Std 188-110A (waveforms). The test software also allowed for channel measurements to help the interpretation of the performance data. FFI joined the tests by September 2001.

Phase 2, January 2002 – August 2002

There were several test goals in this phase.

1. We wanted to measure the performance on point-to-point links of the fast link setup protocol (FLSU) of S4538, and compare it with the performance of 2G link setup represented by Mil-Std 188-141A (ALE).
2. The S4538 FLSU and xDL should be compared with a complete 2G system represented by Mil-Std 188-141A , Fed-Std 1052 and Mil-Std 188-110A on point-to-point links.

¹ Fed-Std 1052 is a modem standard identical to Mil-Std 188-110A, with a data link protocol defined in Annex B. The autobaud capability of the waveforms is used for adapting the data rate and interleaver setting, and the initial data rate was set to 1200 bps with a short interleaver.

3. We wanted to measure the performance of point-to-multipoint link setup. As for phase 1, the test software allowed for channel measurements to help the interpretation of the performance data.

Phase 3, September 2002 – January 2003

The primary focus in this phase was to compare the performance of S4538 with a 2G system based on S5066, ALE and suitable waveforms. Other test goals were to investigate the transmission of IP over S4538, link protection issues, the use of crypto, and time-of-day (TOD) synchronization. However, during this phase QinetiQ ran out of funding, so a reduced number of experiments were run. In early 2003, FFI put focus on integrating the Military Messaging Application (MMHS) with S4538, and results from these tests are documented in another report “Performance testing of STANAG 4406 (Military Messaging) using IP over HF” (2).

6 RESULTS

We will here sum up the experience gained from all tests over-the-air, both national tests and common tests between the three countries.

6.1 xDL versus 2G (Fed-Std 1052 + Mil-Std 188-110A) on a point-to-point link

The first Harris implementation of S4538 provided only the data link functionality (xDL) together with the burst waveforms. Frequency had to be manually selected, and the *type* of xDL protocol (LDL32, HDL3, etc) could also be manually selected. No IP interface was available. The xDL performance was compared with the performance of the Fed-Std 1052 and Mil-Std 188-110A (max gross data rate of 2400 bps), also implemented within the RF-5800H.

Malvern (UK) – Maaldrift (NL), approx 460 km

This is a medium range path. Two-three months of data have been analyzed and averaged. During good propagation conditions (daytime) on this path, the LDL throughput of files of 100 bytes - 1 kbyte was up to 400 bps, and 2G technology was slightly better than the LDL protocol which was appropriate for these file sizes. This was due to the larger initial data rate of 1200 bps for 2G compared to 500 bps for LDL. For file sizes 1 – 50 kbyte, HDL throughput ranged from 500 bps for the smallest file size to 2000 bps for the largest file size. The 2G throughput was a factor 0.5 and 0.75 smaller for file sizes 5 kbyte and 50 kbyte, respectively.

Malvern (UK) – Portsmouth West (UK), approx 170 km

This is an NVIS (Near-Vertical Incidence Skywave) path. Two-three months of data have been analyzed and averaged. During bad propagation conditions at night, the LDL throughput of files of 100 bytes - 1 kbyte was below 200 bps, and now the LDL was slightly better than the 2G technology due to better robustness. For file sizes 1 – 50 kbyte, HDL throughput ranged from 200 bps for the smallest file size to 800 bps for the largest file size. The 2G throughput was a factor 0.5 and 0.75 smaller for file sizes 5 kbyte and 50 kbyte, respectively.

Jørstadmoen (NO) – Kjeller (NO), approx 130 km

This is also an NVIS path, and we used only 20 W during most of these measurements. The following frequencies were used (one at the time): 3.9, 4.8, 6.7 MHz. We collected approximately 2 months of data on this path, from October to December 2001. Various file sizes ranging from 500 bytes to 50 kbyte were transmitted. Noise and SNR were recorded also.

Since a fixed frequency was used throughout the day, the two highest frequencies were obviously above the MUF at night, and there was very little propagation. For the antenna locations during these tests, the noise level at Jørstadmoen was a few dB's higher than at Kjeller, giving higher throughput when transmitting HDL from Jørstadmoen than when receiving at Jørstadmoen. For LDL, the throughput in the two directions was approximately equal, since the robustness of this protocol handled the existing channel conditions.

Transmitting only 20 W on this path turned out to hamper the performance of the HDL protocol compared to 125 W transmissions. For a 50 kbyte file using 125 W, a throughput of 2000 bps was achieved for HDL24 in both directions. A throughput of 1500 bps was achieved for HDL6 and 2G for the same conditions. For small file sizes (<5-10 kbyte) the measured throughput was actually larger than the theoretical curves in Figure 2 and 3 since these curves include the time to link whereas the measurements did not.

As observed on the mid-latitude paths, the 2G technology is better than the LDL protocol for small file sizes and good channel conditions due to its initial data rate setting. However, for worse channel conditions, such as low SNR, the LDL protocol gives better throughput.

To summarize all paths: The measured throughput over-the-air is lower than the theoretical throughput in Figure 2 and 3, even though these figures include the link setup time and the measurements do not. This lower throughput is caused by channel errors and following retransmissions. In conditions where SNR is low, xDL provides higher average throughputs than 2G due to the robust waveform technology. Under disturbed channel conditions where SNR fluctuates, higher throughput is also obtained using xDL instead of 2G. The xDL protocol can more rapidly adapt to changing channel conditions.

The HDL protocol family is equally robust since they use the same waveform. The same applies to the LDL protocol family. However, throughput is influenced by the size of the message to be transmitted compared to the frame size of the protocol as seen by the zig-zag curves in Figure 2 and 3.

6.2 3G (FLSU and xDL) vs 2G (Mil-Std 188-141A and Fed-Std 1052) on a point-to-point link

A new version of the RF-5800H radio software that was released in December 2001 included Fast Link Setup (FLSU) with synchronous scanning using common calling and traffic

channels, Point-to-Multipoint one-way calls and TOD synchronization. Also, Automatic Channel Selection was implemented and the channel selection was based on channel scores which were obtained based on a one-way sounding signal. However, the channel scores were lost when the radio mode was changed, which caused us some problems in the data collection.

Frequency plans consisting of a number of frequencies to be scanned, could now be loaded into the radio. We used two frequency plans consisting of 10 frequencies each, appropriate for day and night, respectively.

6.2.1 Results on mid-latitude paths

The FLSU in S4538 was compared with ALE (Mil-Std 188-141A) on the path Portsdown West – Malvern (170 km) in Figure 7. Optimum addressing lengths (three characters) were used for the ALE, and the scan rate was 5 channels per second. The channel selection was based on link quality analysis repeated at regular intervals of one hour. For FLSU in this case, the next available frequency on the list was selected, independent on channel score (channel scores were lost in 3G mode as a consequence of switching between modes). The frequency list consisted of 10 frequencies. Different paths within the UK, between the UK, NL and NOR were tested.

The example in Figure 7 shows a mid-latitude channel with optimum channel conditions giving an average linking time for FLSU of 6 seconds whereas for ALE the time is 13 seconds. The second example in Figure 8 shows also a mid-latitude channel but with poorer SNR conditions. In this figure the 141A fails to link at several occasions shown as negative Link Setup times. In both poor and good propagating channel conditions FLSU offers a significant improvement in both Call time and Link success compared to ALE:

For good channels (>10 dB) the numbers are: FLSU 6s / 95% and ALE 13s / 60%.

For poor channels (<5dB) the numbers are: FLSU 20-30s / 70% and ALE >50s / 10-30%. The advantages of FLSU are the robust waveforms and the synchronous scanning.

The combination of FLSU/xDL is able to adapt rapidly to the variable HF channel, in contrast to the 2G combination of ALE, Fed-Std 1052 and Mil-Std 188-110A waveforms. There is also a significant increase in throughput using FLSU/xDL as compared with 2G. The throughput improvement is dependant upon file size and channel conditions. The advantages of FLSU/xDL are the robust waveforms and the use of code combining.

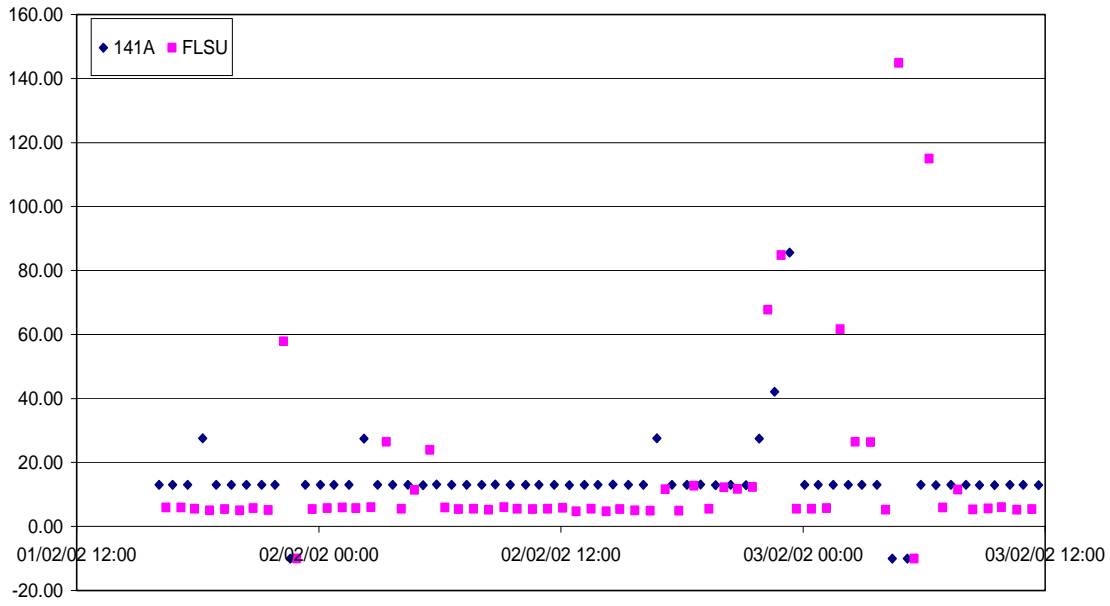

Figure 7 Comparison of Link Setup time for Mil-Std 188-141A and FLSU on Malvern-Porstdown West (170 km), 125 W, February 2002

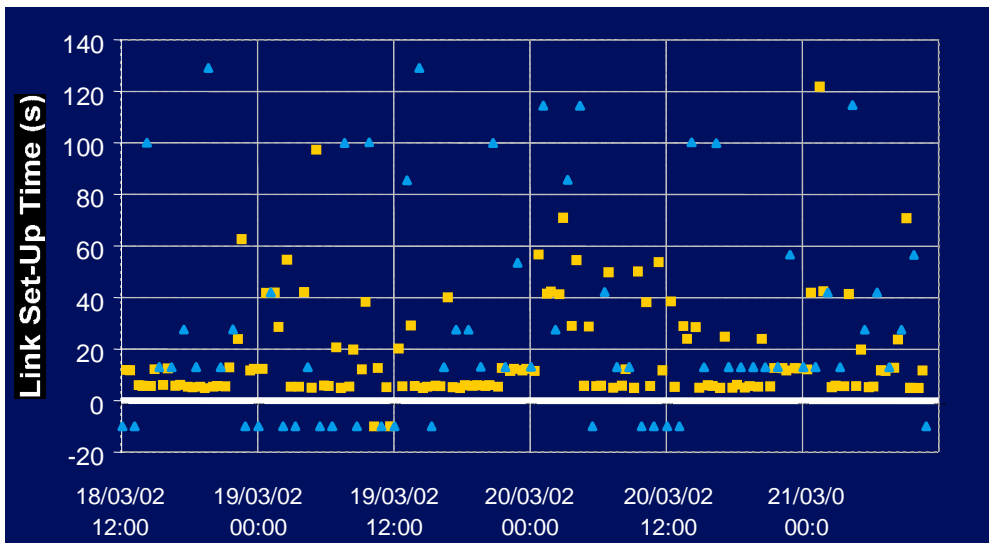

Figure 8 Comparison of Link Setup time for Mil-Std 188-141A (blue) and FLSU (yellow) on Malvern-Cove (120 km), 10 W, March 2002

6.2.2 Results on the high latitude path Jan Mayen – Jørstadmoen (1360 km)

A radio site was deployed at the Norwegian island Jan Mayen from April 2002 until December 2002. We encountered numerous problems with test software and radio hardware during the first months of deployment. The last problem with lost channel scores whenever the radio was switched between 2G and 3G mode was not fixed until the release of new radio software in November 2002, and this new software was never effectuated at the Jan Mayen site. This problem prevented a fair comparison between 2G and 3G since channel knowledge is very important for good performance on a high latitude path. However, we avoided the problem by running only 3G measurements (and 3G Sounding updating the channel scores at regular intervals). Approximately one month of good data on a point-to-point link between Jan Mayen and Jørstadmoen were collected in October/November 2002, in addition to the point-to-multipoint data collected in August 2002 (next section).

Similar antennas were used at the two sites (horizontal broadband dipoles) and 125 W was transmitted. Noise measurements showed that the noise levels were very much the same at the two sites.

Figure 9 shows an example of an hourly schedule that was used. The two sites acted as transmitter and receiver in alternating 5 minutes slots, so the same file was sent in both directions using the same data link protocol. Five minutes in each hour were dedicated for channel measurements and five minutes were used for channel sounding updating the channel scores of the radio. The schedule was repeated 24 hours a day. With HDL protocols, a 5000 bytes file was transmitted, whereas with LDL protocols, a 500 bytes file was sent.

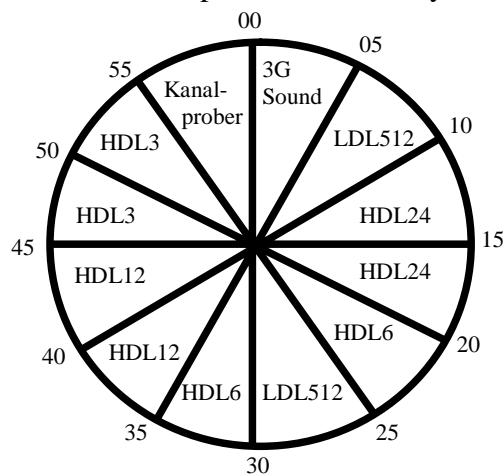

Figur 9 Example of hourly schedule of measurements. The two stations change status as Tx and Rx every five minutes

Even though the high latitude channel conditions shows large time variability, with often difficult conditions at night, there was no ionospheric event giving extreme conditions during the time period analyzed here. In the following we show examples of the data analyzed and focus on some characteristics on this high latitude path. The example day is the 20th of October 2002 which was a geomagnetically calm day with a maximum K-index in Tromsø of 4.

Figure 10 shows a time period between 6 and 12 UT where linking has been difficult for the two first hours of the period. Jan Mayen is the calling station in this example. All ten frequencies in the scan set have been tried without success. We believe this is due to the frequently encountered morning absorption at high latitudes giving very low signal-to-noise ratios. Successful linking is resumed around 8 UT and the linked frequencies are shown.

Time to link for the same day (all 24 hours) is shown in Figure 11. The difficult time period between 6 and 8 UT gives rise to large linking times. Throughout the rest of the day, linking times lie around 20 seconds which are considerably higher than those reported for the mid-latitude path where all frequencies were good and linking was tried on the next frequency in the scan list. However, this figure agrees with the linking time reported for poor channels on the mid-latitude path. No general rise in call time during night hours is seen for this day (there is a small increase around geomagnetic midnight at 22 Hrs), even though this was observed for some of the other days.

Figure 12 shows the data link throughput for a number of HDL (and LDL512) protocols when Jan Mayen (NOB) is the transmitting station. Even though linking succeeded in most attempts (Figure 11), sending the complete message was a less success as seen by the data points located at zero throughput in Figure 12. LDL512 was the most successful protocol agreeing with the fact that LDL uses a robust, low data rate waveform giving a maximum data rate of 400 bit/s. HDL, that uses a less robust waveform, failed to a larger extent to complete its transmission, and was far from achieving its maximum data rate of 3200 bit/s.

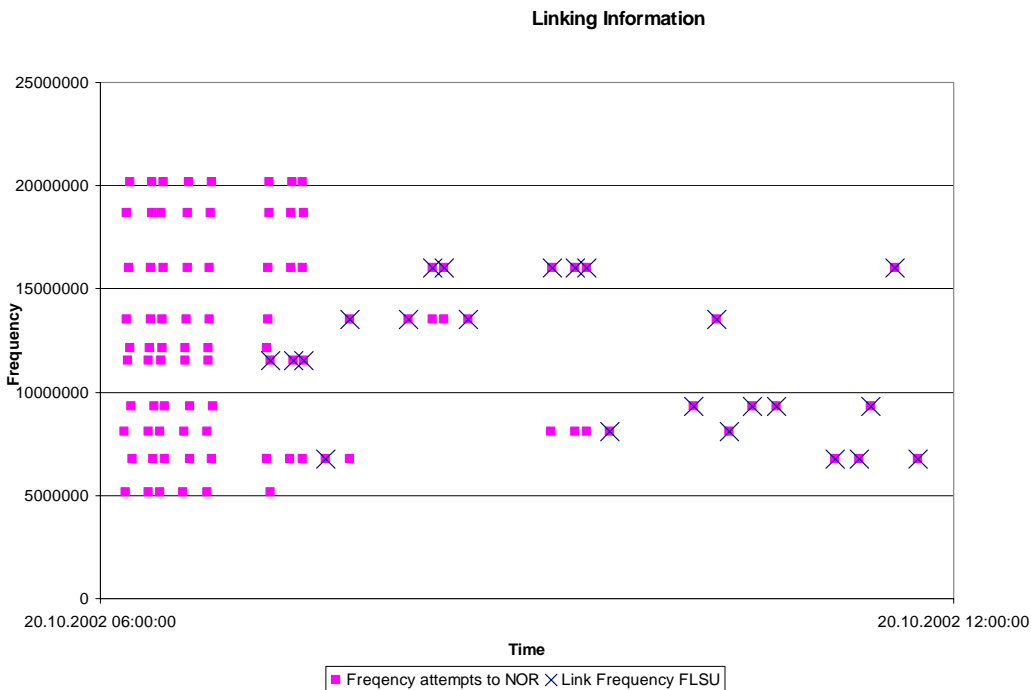

Figure 10 Linking attempts from NOB (Jan Mayen) to NOR (Jørstadmoen) during hours 06 – 12 UT on the 20th of Oct 2002

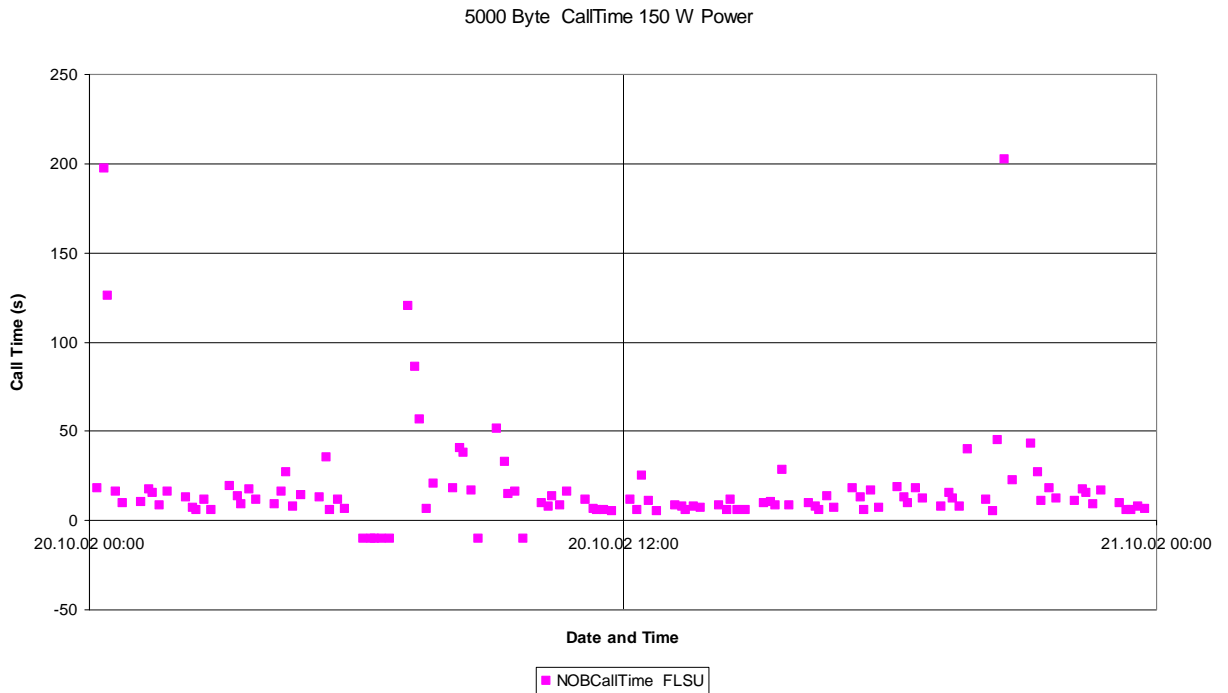

Figure 11 Time to link. NOB (Jan Mayen) is calling NOR (Jørstadmoen). 20th of Oct 2002

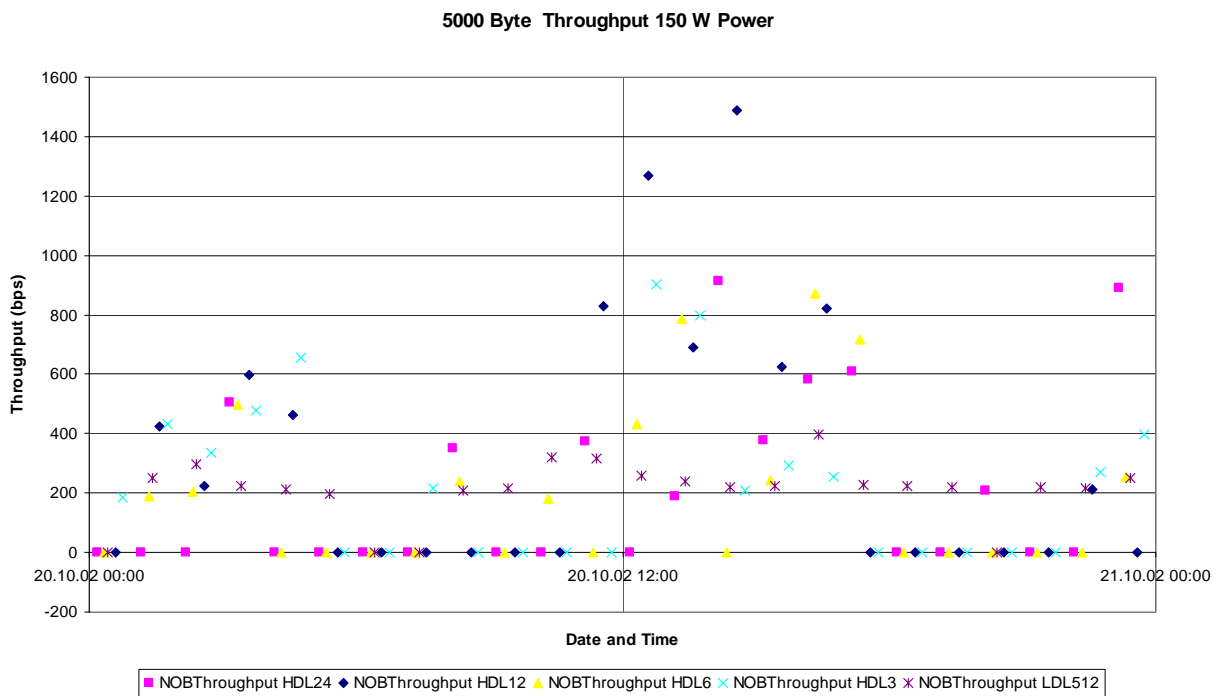

Figure 12 Throughput of various xDL protocols. Tx is NOB (Jan Mayen) and Rx is NOR (Jørstadmoen). 5000 byte message, 20th of Oct 2002

Figure 13 shows the SNR measured by the radio during a transmission. If there was no linking, no SNR has been measured. The figure shows the typical pattern of diurnal variability of SNR at high latitudes; the maximum SNR occurs in the hours after local midday and minima occur

around geomagnetic midnight (22 UT) and in the early morning hours. The throughput in Figure 12 is well correlated with the measured SNR's.

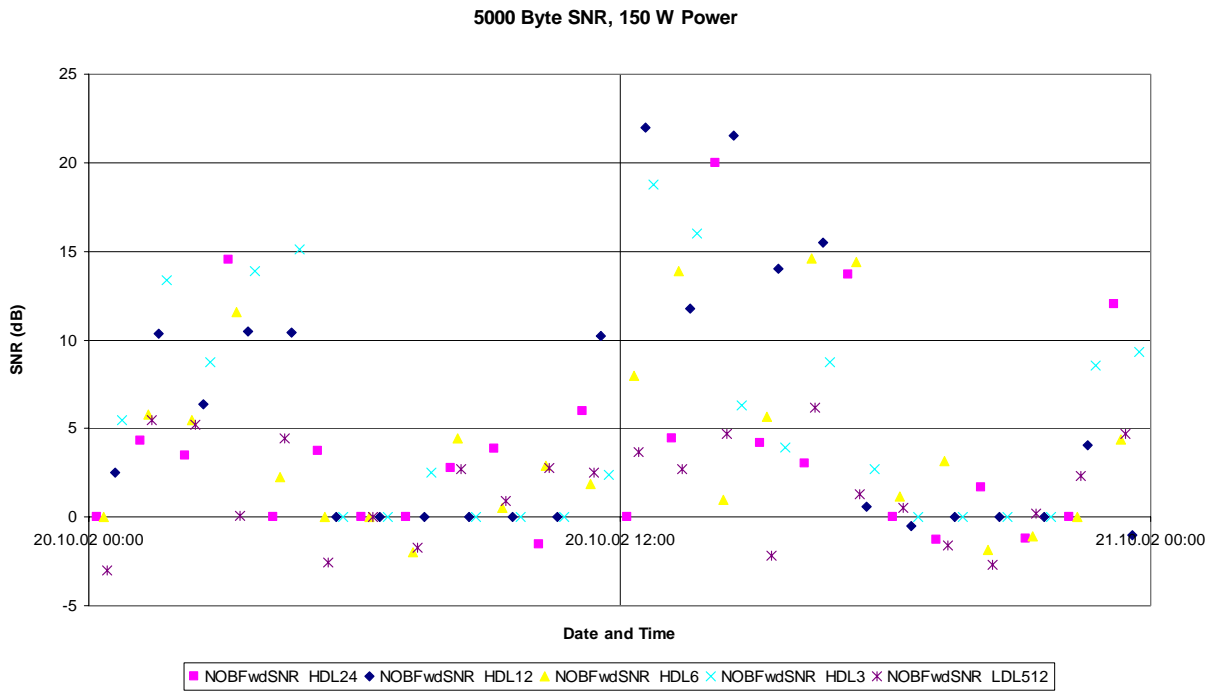

Figure 13 SNR measured at the Rx (Jørstadmoen) during message transfer from Jan Mayen, 20th of Oct 2002

For completeness, the Doppler shift and spread for the same day is shown in Figure 14. This is the channel characteristics measured at the Rx site at Jørstadmoen when channel probes are sent from Jan Mayen. Doppler spread is most of the time below 5 Hz, which is a figure defined in the ITU as a poor channel. However, this Doppler spread is low compared to what it can be on a high latitude channel.

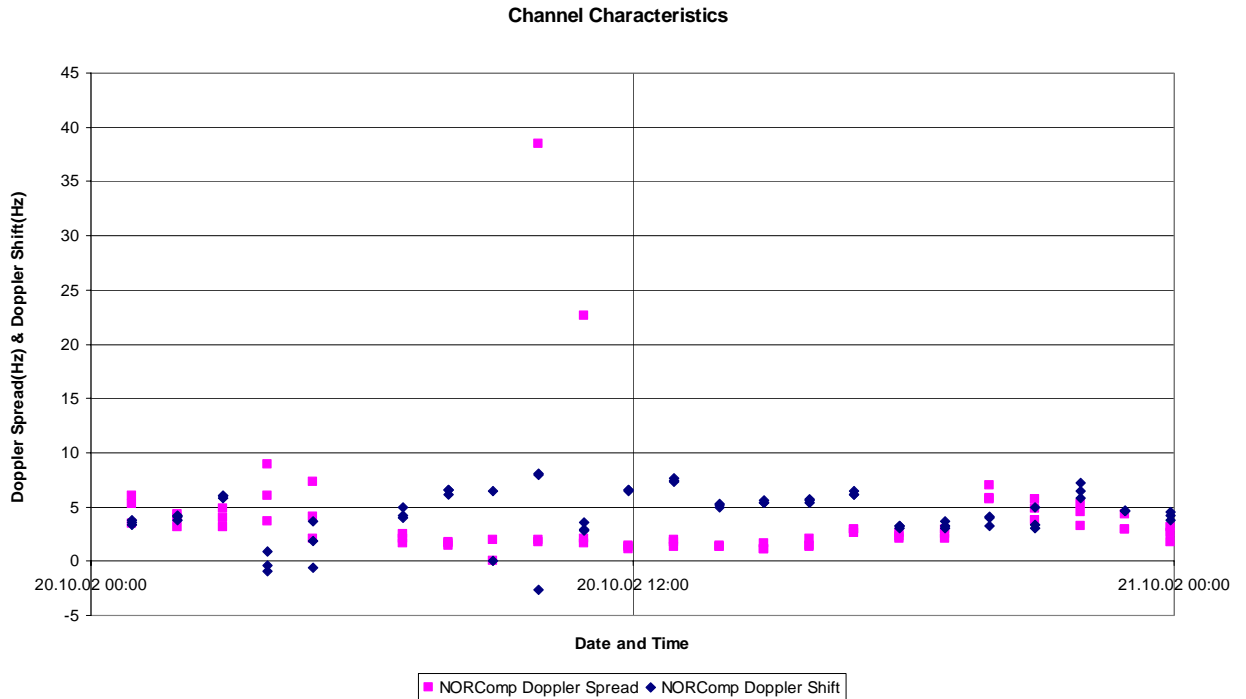

Figure 14 Doppler shift and spread measured at NOR (Jørstadmoen) while transmitting channel probes from Jan Mayen

The performance of S4538 was not symmetric in the two directions of message transfer. We believe the reason for the different performance was a possible loss in the cable connecting the antenna to the power amplifier at Jan Mayen. The cable was more than 100 m long and a loss of 2 dB was measured at 20 MHz. A loss in this cable would cause less power to be transmitted from Jan Mayen resulting in a low SNR at Lillehammer, whilst keeping the SNR measured at Jan Mayen quite high. The result of this was:

- Higher throughput measured when Jørstadmoen transmitted
- The 3G sounding from Jørstadmoen to Jan Mayen is heard well at Jan Mayen resulting in an update of channel scores at Jan Mayen
- Lower throughput measured when Jan Mayen transmitted and not a very good update of channel scores at Jørstadmoen
- The call times from Jan Mayen were shorter than those from Jørstadmoen due to a better update of channel scores at Jan Mayen

Asymmetric behaviour on a path is quite common, for instance on a shore-ship link. However, separate statistics must be kept for the two directions of transmission. In the following, two weeks of data (all 24 hours) have been averaged and shown in Tables 2 and 3 for the respective directions. The tables also show the average of the best and worst day.

Table 2 Averaged results, NOB (Jan Mayen) as Tx, two weeks of analyzed data, Oct –Dec 2002

NOB (Jan Mayen) as Tx	Average	Best day	Worst day
Number of link attempts (also incl. non-successes)	3,0	1,2	4,8
Link success [%]	84	100	59
Call time [s]	19	11	31
Send success [%]			
HDL24	36	42	0
HDL12	27	46	0
HDL6	26	46	0
HDL3	20	54	6
LDL512	68	100	54
LDL256	69	93	63
LDL128	68	100	58
LDL64	72	100	71
Throughput [bps]			
HDL24	327	501	0
HDL12	388	695	0
HDL6	321	420	0
HDL3	387	418	325
LDL512	144	165	112
LDL256	126	148	90
LDL128	110	133	104
LDL64	96	105	82

Table 3 Averaged results, NOR (Jørstadmoen) as Tx, two weeks of analyzed data, Oct –Dec 2002

NOR (Lillehammer) as Tx	Average	Best day	Worst day
Number of link attempts (also incl. non-successes)	3,6	1,3	5,5
Link success [%]	87	100	63
Call time [s]	30	9	58
Send success [%]			
HDL24	48	58	31
HDL12	42	67	41
HDL6	47	75	50
HDL3	40	71	17
LDL512	78	100	54
LDL256	83	100	58
LDL128	80	100	54
LDL64	84	100	67
Throughput [bps]			
HDL24	513	575	356
HDL12	647	724	543
HDL6	597	771	600
HDL3	464	532	351
LDL512	156	171	128
LDL256	139	165	112
LDL128	127	132	106
LDL64	100	117	79

The results are clearly worse than those reported on the mid-latitude paths. Some broad conclusions on this high latitude path are:

- The S4538 linking is very robust. 85% of the link attempts on this path were successful, and FLSU is able to establish links at SNR's down to -7 dB.
- Call times are fairly high, approximately 20 s for the most favourable direction, and very dependant upon good knowledge about the channel quality. Sounding is important to reduce call times.
- For the data link protocols, HDL achieved a 45 % send success at a throughput rate of approximately 600 bps, and LDL a 80 % send success at a throughput rate of 125 bps (for the most favourable direction).
- Low SNR on these channels was the factor limiting the performance in the data set studied here, the effect of Doppler and delay spread seemed to be less harmful.

6.3 Point-to-Multipoint one-way LSU

In STANAG 4538, a two-way Point-to-Multipoint link setup with roll-call response is defined. A one-way point-to-multipoint link setup is also mentioned in the STANAG, and this protocol was first implemented by Harris. Both protocols are synchronous. These protocols are defined for circuit switched data and voice, not for packet switched data such as IP. The first protocol was tested by us in the last week of August 2002, including the two UK stations UKB and UKR, the two Norwegian stations NOB (Jan Mayen) and NOR, and one Dutch station, NEB. However, the NEB station got a problem with power levels, and a limited amount of data was collected from this station. Also, the Jan Mayen station ran a different version of the software than the other stations for some days during the period, but the data was still usable to a large extent.

The schedule for the tests was as follows:

- All stations measure the noise at all frequencies in the scan set
- Each station in turn performs a one-way sound (3GSound) at all frequencies in the scan set and updates channel scores
- Each station in turn sends a one-way LSU to the other members of the net at a selected frequency (two minutes are allocated to each LSU attempt)
- The channel scores are erased and the schedule starts from the beginning

Using the one-way sounding, each station was able to update its knowledge of channel quality to all other stations in the network and make an optimal choice of frequency for its own transmissions. This use of sounding and optimal channel selection was compared to not using channel scores at all, only place a one-way call at the next available frequency in the scan list. The performance metric for these tests was the percentage of Call successes (call was heard and radio enters into linked state). Call time was also recorded but in this one-way link set up it only reflects the time from initiation of a call to the call is attempted at the chosen frequency. The frequency is selected based on knowledge of channel scores to all nodes to which the call will be addressed.

Figure 14 shows the percentage of receive successes at UKB (Malvern) for various measurement periods during the 12-day measurement campaign. The text below each family of vertical bars indicate test characteristics such as High power, No sounding. Each bar represent the percentage of receive successes out of the total number of link attempts to UKB from the respective other nodes in the network. Jan Mayen was not operative in the first set of data and Maldrift had a problem with reduced transmitted power during the whole period.

Throughout all tests, NOR (Jørstadmoen) had the greatest success in placing a call and linking with all the other stations. The mean linking success over all tests for NOR was 83%. This is explained by NOR being the geographically most central node within the network. In figure 14 we see that using sounding for updating channel scores, increases the success rate. Even at 10 W transmitted power (two rightmost families of bars) the success rate was quite high.

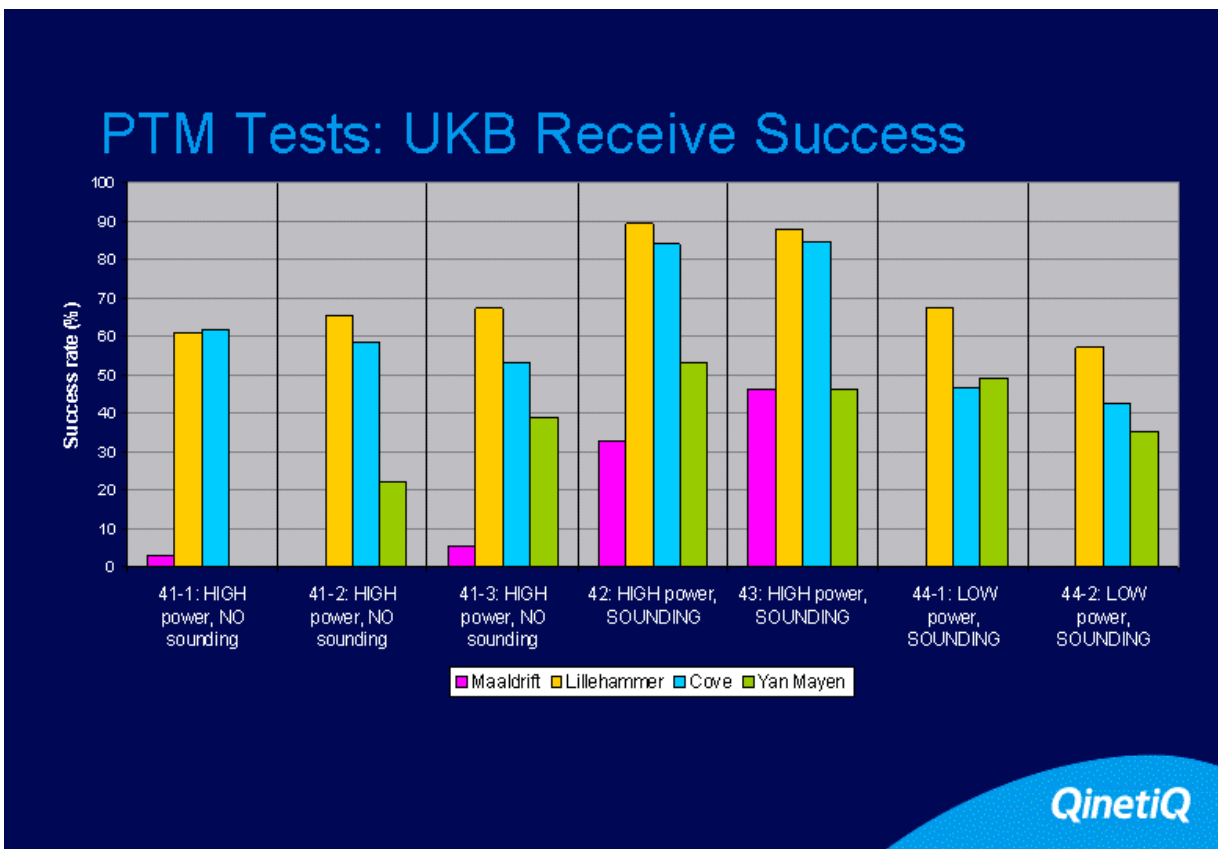

Figure 14 Link successes with UKB (Malvern) when other stations are placing a one-way call. Different measurement periods and test characteristics.

The next figure (Figure 15) shows two days of measurements of one-way calls from UKB to the other nodes in the network. If a call from UKB was successfully received at the respective station, that station is marked with a vertical bar at the respective time of measurement. Multiple receptions are stacked on top of each other. During this time period, sounding was used and the call time also marked in the figure indicates the time to arrive at the selected frequency.

NOR (Jørstadmoen) shown as yellow, hears UKB (Malvern) very well.

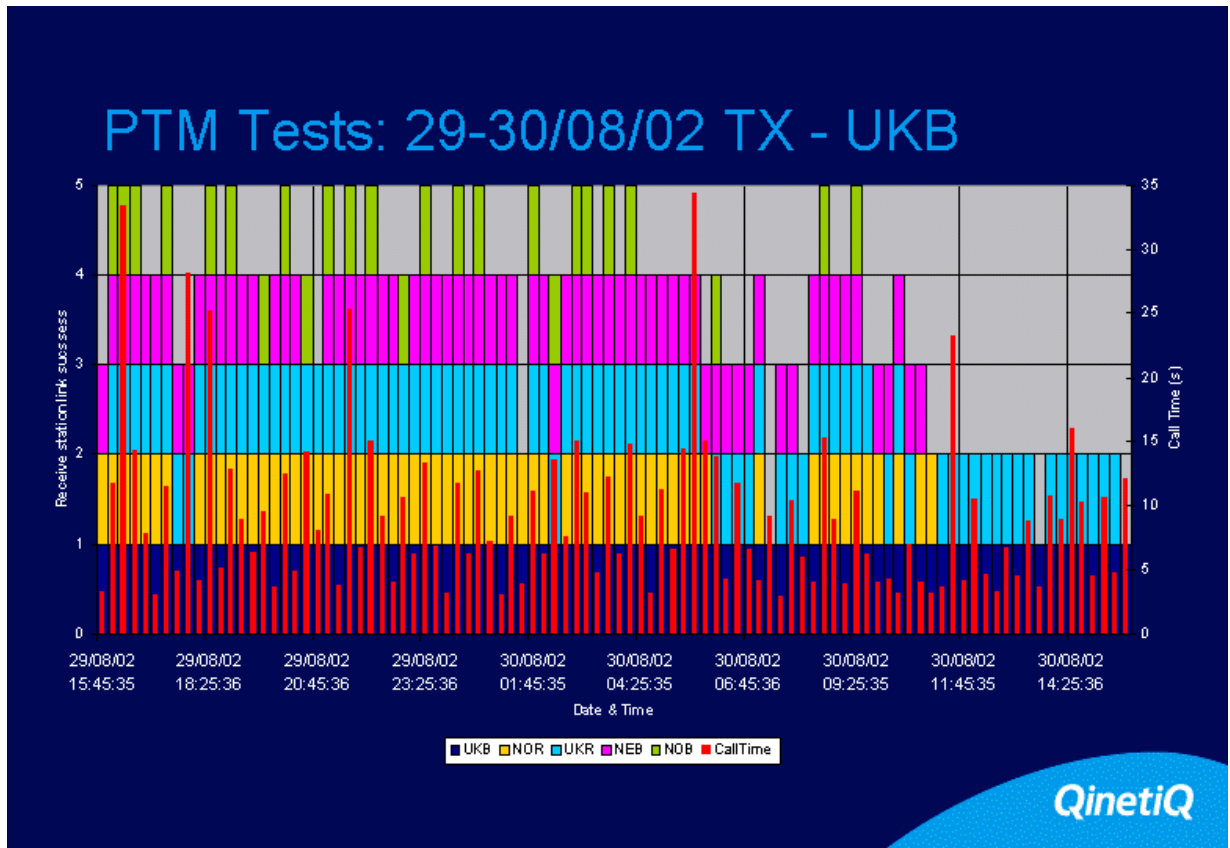

Figure 15 Receive station link successes when UKB (Malvern) is placing a one-way call. Two days of measurement using 125 W power and sounding.

The effect of using sounding and updating of channel scores for the optimum frequency selection was evaluated. A period of using no sounding is shown in Figure 16. The caller merely places a call at the next channel in the scanning list. Another period where sounding and selection of a frequency based on channel scores was used, is shown in Figure 17. The station names on the abscissa are the transmitting stations, and the vertical bars show the percentage of receive success at the other HF nodes. The Jan Mayen data is omitted in Figure 17 because Jan Mayen did not make use of channel scores like the other stations in this period.

When channel scores were used for channel selection, different conclusions can be drawn for good and poor channel conditions:

- For good propagating conditions, average call time is *higher* when channel scores are used to select optimum channel in scan list. This is due to the waiting time for the optimum channel in the scan list, and the fact that the burst waveform used for linking is sufficiently robust to operate proficiently on a variety of channels. The increased linking time results in lower throughput for small messages (<1000 bytes).
- When SNR is generally low across the frequency allocations, test results have indicated that channel selection based on channel scores greatly improves linking times. This is due to the lower number of call attempts. In addition, Throughput has been shown to be

higher as the channel chosen is likely to offer optimum propagating conditions for message transfer.

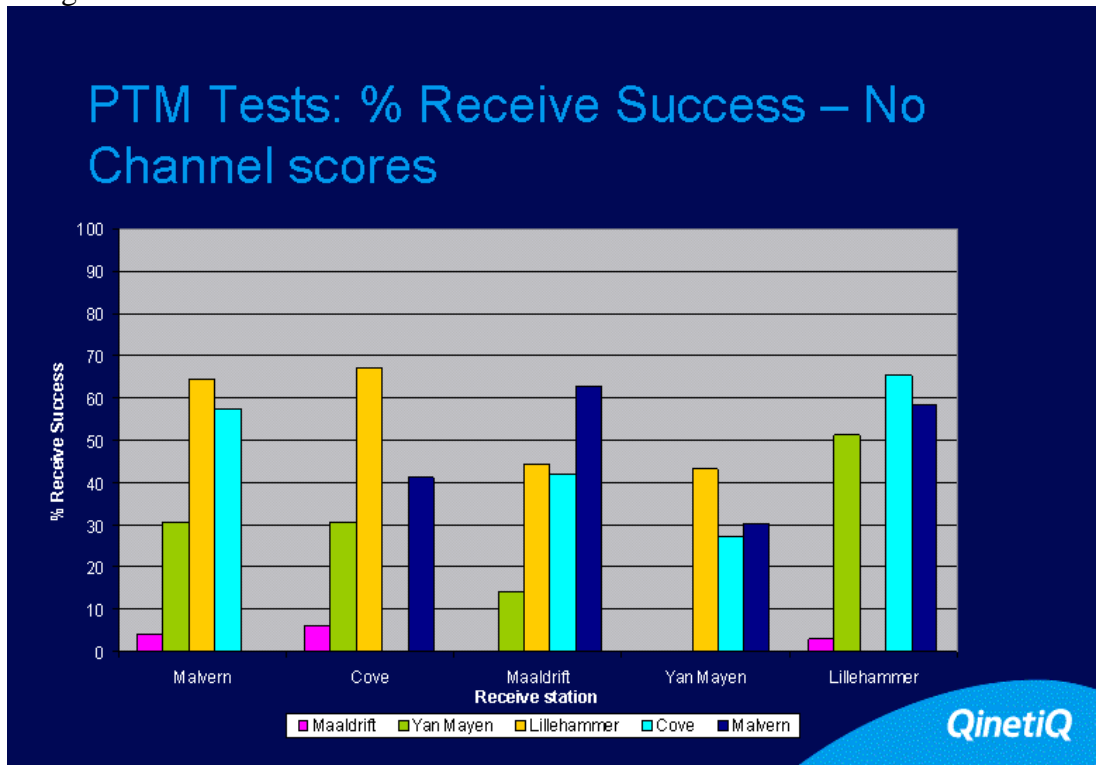

Figure 16 Receive successes at respective stations when next frequency in the list was selected. 125 W transmitted power.

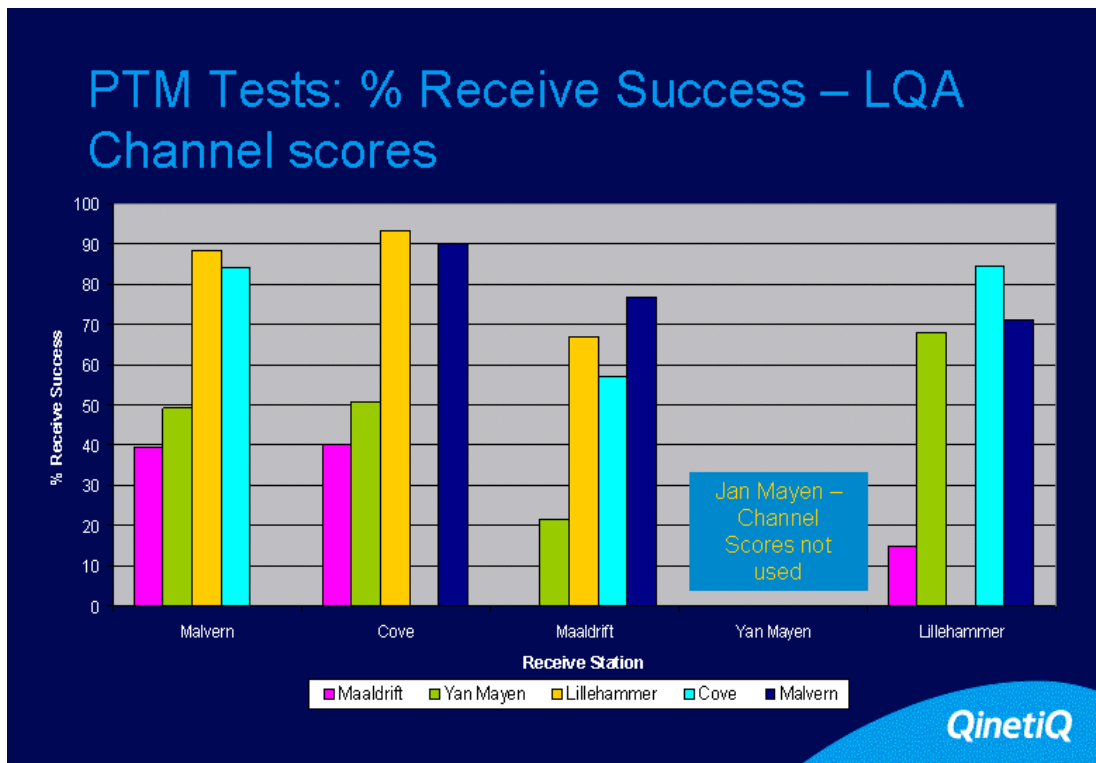

Figure 17 Receive successes at respective stations when frequency was selected based on channel scores. 125 W transmitted power.

6.4 TOD synchronisation

S4538 is designed to be a synchronous system with accurate time of day (TOD) provided by a GPS signal. If GPS is not available at the radio, the radio can obtain synchronisation either by a sync request to a station that has accurate time, or by a sync broadcast from a nominated TOD server enabling passive TOD acquisition. The TOD_Response PDU is precisely timed and conveys the accurate minutes and seconds TOD information. The TOD client obtains accurate time to within 80 ms, which is considered the maximum propagation delay.

A limited number of measurements have been taken on the path Malvern (UK) to Maaldrift (NL) to test the quality of the TOD acquisition functionality. Both TOD Broadcast and TOD Response/Request protocols have been tested with scheduled TOD transmissions at 1, 4, 8 and 24 hour intervals. The performance metrics were the *clock synchronization quality* reported over the Telnet connection and comparative FLSU/xDL call times and throughput using both GPS and non-GPS synchronized units.

The conclusions from a few days of measurements were that both TOD Broadcast and Response/Request protocols have proved effective as a means of maintaining network synchronization. There were no noticeable reduction in FLSU/xDL performance as a result of using non-GPS TOD synchronization at the TOD update intervals tested.

As to the use of the two different TOD mechanisms, TOD Broadcast is suitable in high capacity networks with relatively large number of participating units. TOD Request/Response is recommended for use in smaller, lightly loaded networks. The interval between scheduled TOD exchanges is dependant upon the quality of the radio internal clock.

7 CONCLUSIONS

The aim of these tests have been to evaluate the performance of HF STANAG 4538 (Automatic Radio Control System) used over-the-air. It is expected that the performance over-the-air is lower than performance measured in the lab under ideal channel conditions or by using a channel simulator. The testing was initiated by three of the participating nations in the NATO standardization group; the UK, NL and Norway. Five radio stations were established in the three countries, including a Norwegian station at Jan Mayen to incorporate high latitude paths as well. The measurements documented here were conducted in 2001/2002 and the results have been reported in the NATO standardization group and at various HF conferences.

The test results reported here are influenced by the *implementation* of STANAG 4538, and represent only a rough figure of what can be expected from the 3G HF technology. We used the implementation from Harris in their RF-5800H product, and Harris has provided good radio support to the tests.

The performance of 3G was compared to the performance of 2G HF technology represented by Mil Std 188-141A (ALE), Fed Std 1052 (datalink protocol) and Mil Std 188-110A (modem). These standards were also embedded in the radio software along with STANAG 4538. Note that STANAG 5066 (data link protocol) which represent the most widespread 2G technology was not included in these comparisons, but is considered in the companion report (2).

Testing the data link protocols on mid-latitude paths, the following can be concluded:

For file sizes 1-50 kbyte the HDL protocols of STANAG 4538 gave a 100-150% better throughput than 2G during both good and poor channel conditions. The measured average throughput increased with file size and for the largest file sizes the throughput was approximately 2000 bit/s. For file sizes below 1 kbyte the performance of LDL was similar to 2G during good channel conditions and improved the throughput slightly during poor channel conditions. So the conclusion is that STANAG 4538 outperforms 2G by more than doubling the throughput for large files and showing robust performance during bad channel conditions.

Testing STANAG 4538 on the high latitude path, the following can be concluded:

A considerably worse data link performance was observed on the high latitude path than on the mid latitude paths. When all data of a two week period was averaged, only a throughput of 600 bps was achieved sending a 5 kbyte file using HDL. However, the robust data link protocol LDL gave a send success of 70-80 % sending a 500 byte file.

The link setup procedure in STANAG 4538, FLSU, has big advantages compared to 2G. The linking time is considerably reduced, and robustness has increased. On good channels an average of 6 seconds (when linking on the next available frequency in the list) and a link success of 95 % was achieved. For 2G the same numbers were 13 seconds and 60 % success. For poor channels including the high latitude path, linking times of 20-30 seconds and a link success of 70-85 % were measured.

When testing the one-way point-to-multipoint link setup between all nodes in the network, connectivity was achieved between all the nodes. Sounding and frequency selection based on channel scores had great impact on the link establishment time. For good propagating conditions where most frequencies in the frequency set were available, linking was most efficient using the next frequency in the list without consulting channel scores. For more variable channel conditions, sounding and selecting frequency based on channel scores gave the fastest linking. The Norwegian radio site at Jørstadmoen had the greatest success in placing a call and linking with all the other stations. This is explained by NOR being the geographically most central node within the network.

There were no noticeable reduction in FLSU/xDL performance as a result of using non-GPS TOD synchronization at the TOD update intervals tested (1, 4, 8, 24 hour intervals).

One of the aims of the testing was to provide feedback for future enhancements to STANAG 4538. It has become clear that there is a severe data rate limitation in the waveforms used. Also, there are inefficiencies in the synchronous format of the xDL protocols. For good

channels there is a potential for improved throughput by using other waveforms and removing the inefficiencies of the data link protocol. This has now been proposed by Harris with the new HDL+ protocol. This protocol will be standardized in a new edition of STANAG 4538.

Through the testing it has also become evident that sounding and use of channels scores is an important tool for rapid linking at a good frequency. Sounding procedures are now also proposed for standardization. We have seen that the channel selection algorithm which is part of the implementation, is also very important for efficient linking. We have provided Harris with feedback on the performance of their linking algorithm.

There are many aspects of the radio that has not been tested. The list includes:

- Asynchronous calls and link setup
- FLSU for circuit switched data on a point-to-point link
- Link protection
- Non-ARQ transfer on Point-to-Multipoint links
- Network capacities (this is addressed in (5))
- Digital and analogue voice services

Messaging using FLSU/xDL in conjunction with the Harris proprietary Wireless Messaging Products (RF-6710W and RF-6750W) has been addressed by our colleges at TNO in the Netherlands in (6). Transparent IP packet delivery using S4538 is addressed in a companion report (2).

References

- (1) Jodalen V, Otnes R, Solberg B, NATO standards for HF communications – an overview and technical description, *FFI/Rapport-2004/02015*, 2004
- (2) Jodalen V, Solberg B, Grønnerud O K, Performance testing of STANAG 4406 (Military Messaging) using IP over HF, *FFI/Rapport-2005/01183*, 2005
- (3) STANAG 4538, Technical standards for an automatic radio control system (ARCS) for HF communication links (Edition 1), NATO, 2000
- (4) STANAG 5066, Profile for High Frequency (HF) Radio Data Communications, Version 1.2
- (5) Koski E N, Benedett T E, Peach E A, Postema L D, STANAG 4538 implementation and field testing lessons learned, *IEE Conference Publication No 493*, 9th International Conference on HF Systems and Techniques, pp 256-261, Bath, UK, 2003
- (6) Ponsioen C, Hoefsloot P, HF-Radio: Ontwikkelingen en Toepassingen ARCS project Fase 3 en 4, *TNO reportnummer 33425*, 2004

Appendix A

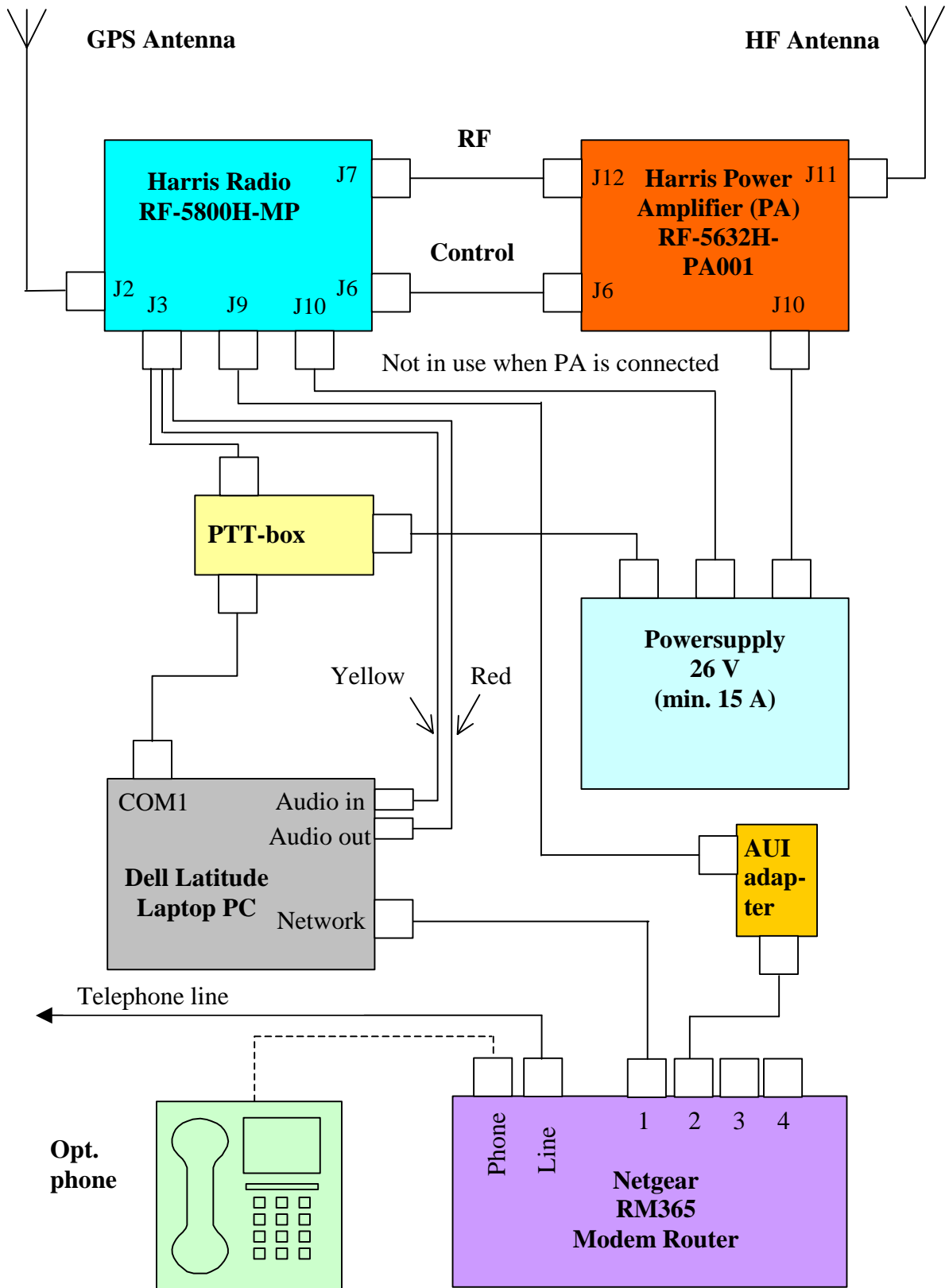

Harris RF-5800H ARCS radio test setup

Appendiks B

RF-5800H – Serial Port PTT Activator

The Serial Port PTT Activator hardware is mounted inside an Eddystone 27134 instrument case. Below the electrical wiring diagram is shown. The components are mounted on a piece of “Veroboard” – fiberglass with copper conductors. The external +26 V DC power is regulated down to the +5 V used by the level converter. A 3-terminal regulator is used for this purpose.

The RTS (Request To Send) signal of the COM1-port is level converted and used as PTT (Push-To-Talk) signal to the RF-5800H-MP radio. When channel probes and CW (Continuous Wave) are transmitted, the radio is brought into transmit mode by activation of this signal. The channel probes and the CW signals are generated by a sound card hosted by the Control PC.

